

## PRÜFTECHNIK News

## Reducing pump vibration

Centrifugal pumps can be found in almost every industrial application. In these pumps, the fluid is swept along by a rotating impeller and forced outward onto a circular path. The absorbed kinetic energy is converted to pressure energy in the outlet area of the pump housing. To achieve the necessary differential pressures in the various media, flow rates of 10–100 m/s are standard, which can generate strong vibrations. In

addition, centrifugal pumps are increasingly being operated at variable speeds to save energy. This further increases their tendency to vibrate.

We have therefore dedicated this issue of the Telediagnose.com magazine to centrifugal pumps. We will show how these pumps can be monitored to detect disturbance vibrations at an early stage, enabling the implementation of specific measures to reduce vibrations. ■

## Condition Monitoring Service

## Beating in a pumping station

Dr. Edwin Becker

If two vibrations of a similar frequency are superimposed, beating occurs. This phenomenon is clearly audible in the acoustics. The tone, which is made up of two individual tones of slightly different frequencies, changes its volume at the beat frequency, rhythmically becoming louder and softer.

Due to the high amplitudes that this can cause, beating generated by two neighboring machines can lead to enormous vibration damage and even machine failure. Because the cause of beating cannot always be eliminated, it is important to keep its damaging effects as small as possible.

The principle of beating and the beat frequency are illustrated in Fig. 6 and can be demonstrated in a simulation. Beating can also be detected in the display of FFT vibration analyzers. The recorded time signals of the vibration velocity and other measured quantities must be of sufficient length. If this type of analyzer is not available, you should become sceptical if amplitudes fluctuate wildly.

This was the case at a pumping station. The operator detected conditions with strongly fluctuating machine and building vibrations. The source was thought to be the pump and an inadequate building foundation. In the control room, the sense was that the vibration intensity was linked to how the

pump was operated and that the vibrations only occurred during high pump output. But why? Systematic vibration analyses were contracted with the PRÜFTECHNIK Machinery Service. The basic measurements revealed a number of unfavorable conditions that led to pronounced building vibrations.

### The pumping station concept

In the pumping station, the pressure increase is achieved in three consecutive

centrifugal pumps that run at different speeds. Pump 1 is the slowest, pump 2 runs somewhat faster, and pump 3 is the fastest. On the measurement day, pumps 2 and 3 had a relatively high vibration level when running at a high delivery rate. It dominated the first order in the vibration velocity.

Measurements of the building revealed additional beating in the vibration velocity. Beating changed as the pump speed increased. The operating

### In this edition:

**Reducing pump vibration**

**Beating in a pumping station**

**Online monitoring at the Berlin Wasserbetriebe**

**Detecting cavitation in pumps**

**Analyzing sources of noise**

**Aligning vertical pumps correctly**

**The toughest vibration standard for centrifugal pumps**

**News**



Fig. 1: Vibration measurement on a pump

mode of the pumps also had an influence on the beating. It could be shown that the beating was influenced by the pressure ratio of the pumps to each other. When only pumps 1 and 3 were operated together, the beating was reduced (see Fig. 4). However, this was not the solution the operator was looking for. On the contrary, increasing the delivery rate further is the order of day. Therefore, avenues were sought to actively reduce vibration.

**Imbalance**

The vibration analyses showed that relatively strong rotational vibrations arose as the motor speed increased (1st order). The balance condition was checked. In the process, it was noticed that keys in the couplings protruded or were missing altogether. One of the first measures was to correct this situation. But this was not the only issue.



Fig. 2: Vibration measurement with VIBXPERT®

**Critical speed**

The motor type in use was not free of natural frequencies in the operating speed range for which it was designed. At approx. 3600 rpm, the motor even



Fig. 3: Protruding key in a coupling

passed through a bending critical speed that led to a marked increase in amplitude peaks on the motor. Phase jumps were also found in the coast down curves.

**Precision balancing**

A precision balancing procedure was performed. This reduced the vibration amplitudes and beating was no longer

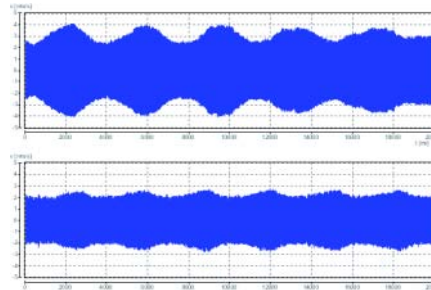

Fig. 4: Beating in the building with the pumps being run in different modes

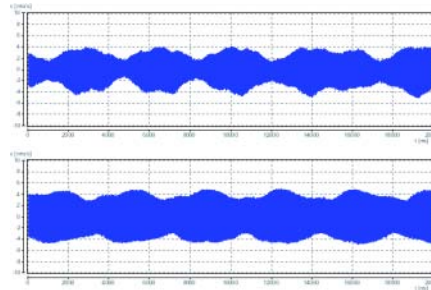

Fig. 5: Beating in the pump foundations of pumps 2 and 3

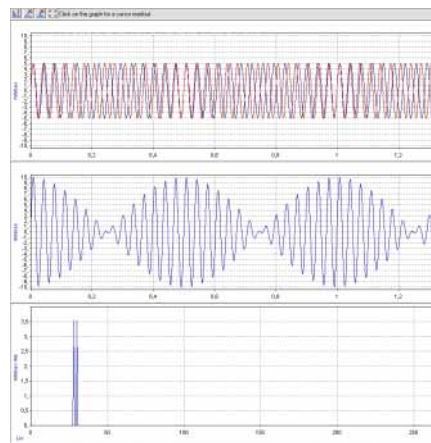

Fig. 6: Simulated beating of two neighboring frequencies (from the ISO-certified vibration seminar that PRÜFTECHNIK offers in Ismaning or on customer premises).

noticeable in the building. Ultimately, beating in the area of 6 mm/s remained when operating at critical speed, which is why this speed could not be cleared for continuous operation. Extensive reconstruction or the use of a motor without natural frequencies was a recommendation PRÜFTECHNIK had to make. It was also recommended that the new pump motors meet the requirements of EN ISO 13709. ■

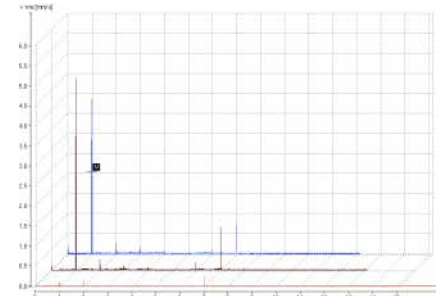

Fig. 7: Order spectra – measured on three pump units



Fig. 8: Employee of PRÜFTECHNIK Machinery Service working at precision balancing the machinery

**Preview**

- Our next issue will focus on fans
- Temporary Telediagnosis Service
  - When the kiln fan trips
  - Acceptance measurements on cooling tower fans
  - Monitoring bearing lubrication using vibration measuring equipment
  - Measuring load resonance curves without shutting off the exhaust fan.

Condition Monitoring Application

# Vibration-based Online Condition Monitoring at the Berlin Wasserbetriebe

Matthias Luft

The task of these water and wastewater utility companies is to provide a safe and reliable drinking water supply and to dispose of wastewater in an environmentally friendly manner. Typical application areas for Condition Monitoring instrumentation are illustrated in Fig. 1. Especially the failure of one of the centrifugal pumps can endanger the reliability of the water supply and wastewater disposal and impair production stability.

To minimize the risk of machine failures, the Berlin Wasserbetriebe have for many years employed Condition Monitoring of machines and systems on the basis of vibration measurements, initially only with mobile data collectors and more recently, since 2008, using permanently installed Condition Monitoring Systems.

Today, 44 machine units, mostly large pumps in sewage pumping stations and treatment plants, are monitored with VIBNODE® (Fig. 1). More machine trains will be equipped this year.

VIBNODE® is an Online Condition Monitoring System for diagnostic vibration monitoring. The objective is to detect damage development at an early stage. Damage becomes visible in changes in machine vibration and noise, and gradually increases over days, weeks or months. The following characteristic values are measured every few minutes:

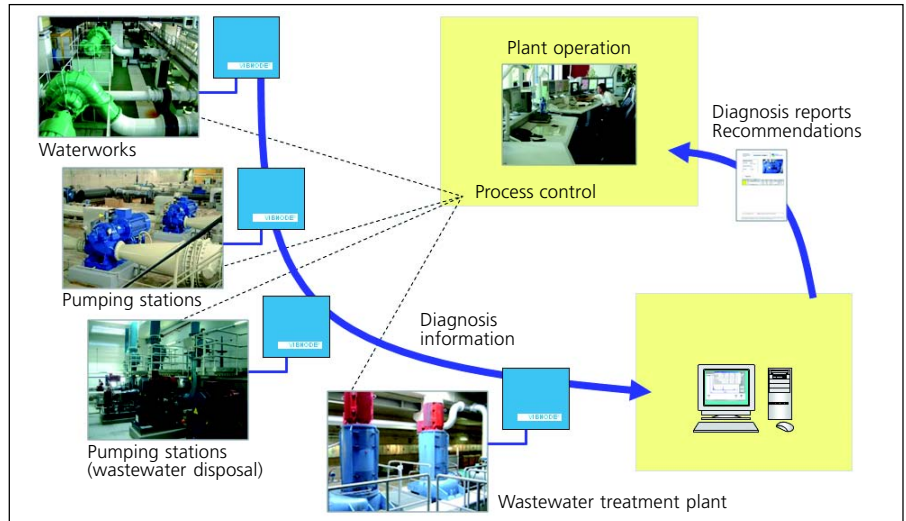

Fig. 1: Condition Monitoring application at the Berlin Wasserbetriebe

- ▷ Vibration severity as per DIN ISO 10816-3, for monitoring low frequency machine vibrations up to 1 kHz => levels increase if there is an imbalance or alignment error
  - ▷ Vibration acceleration, for monitoring machine noise up to 10 kHz => levels increase in the event of lubrication problems, bearing wear and gear tooth damage
  - ▷ Special roller bearing characteristic values (characteristic band values of the envelope spectrum) => levels increase with raceway damage in the roller bearing
- In addition, VIBNODE® measures en-

tire vibration spectra for in-depth diagnosis on a daily basis and when threshold values have been exceeded.

The machine units are equipped with permanently installed vibration sensors on the main bearings. In addition, the PLC obtains important operating characteristic values via a field bus coupling in order to correlate the vibration-based diagnostic data with machine operating states (Fig. 3):

- RPM
- Suction pressure
- Pump discharge pressure
- Performance
- Flow rate

Because waterworks, intermediate pumping stations und wastewater treatment plants are distributed over a large area, it was decided to network the VIBNODE® systems by means of data eMails that transfer data by one of the following routes:

- By modem if there is a telephone line
- Using an Ethernet connection if there is a LAN
- By GPRS modem if there is no communications structure.

The data are automatically transferred to the 'Diagnosis' server PC and archived there in a diagnosis database by OMNITREND®, the central software for vibration diagnosis. Specialists from the 'Central maintenance' department

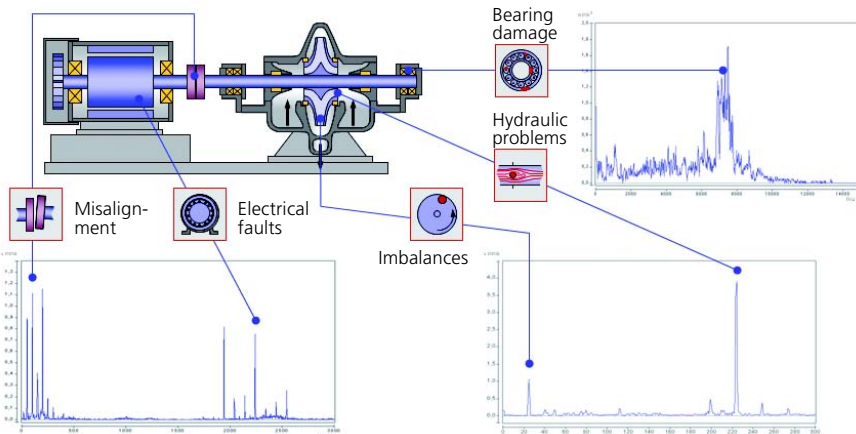

Fig. 2: Causes of vibration excitation that are monitored by VIBNODE®.

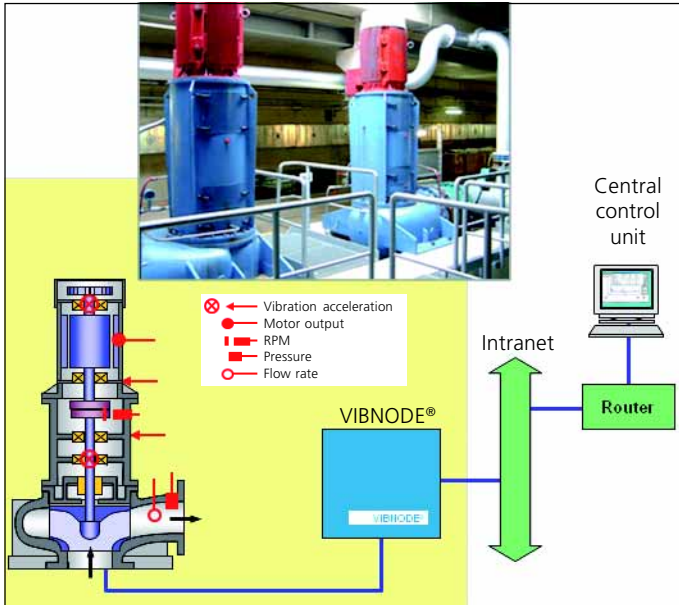

Fig. 3: Example: Monitoring of a recirculating pump for an aeration basin in a wastewater treatment plant

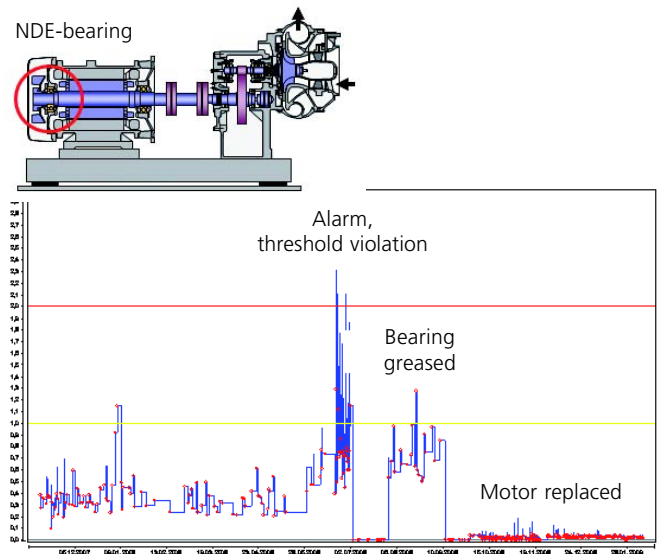

Fig. 4: Trend on a damaged NDE-bearing of a turbo blower until it is changed

evaluate the measurement data using vibration diagnostic methods. Violations of thresholds are immediately and directly sent to the control unit and dispatched to the personnel on call in an alarm eMail. At any time, the operator can determine the current state of the machinery by viewing the diagnosis reports.

How important Condition Monitoring is for machine units was clearly demon-

strated in a recent incident at a wastewater treatment plant (Fig. 4). After a relatively brief increase in roller bearing characteristic values, VIBNODE® signaled an alarm at the NDE-bearing of a drive motor. After relubrication did not lead to significant improvement and the vibration diagnosis signals pointed to advanced bearing wear, the motor was replaced. An examination of the bearing showed considerable wear due to poor

lubrication caused by resinified or carbonized grease. A sudden failure of this machine train would have disturbed the sensitive biological equilibrium in the settling tank, interfering with the performance of the treatment plant. As a follow-up measure, the lubricating grease was changed to optimize lubrication at high bearing temperatures. ■

Condition Monitoring Basics

## Detecting cavitation in pumps

Marcel Kenzler

Cavitation refers to the formation of cavities and bubbles in fluid. Centrifugal pumps are subject to gas and vapor cavitation. In gas cavitation, gas bubbles arise during fluid entry if local pressure drops below the saturated vapor pressure. Vapor cavitation occurs when the vapor pressure of the fluid is reached in the pump working chamber. Vapor bubbles not only reduce the rate of delivery, but they implode in areas of higher pressure to cause pressure surges. This can cause cavitation erosion or even destroy the pump. Cavitation can be detected in acceleration FFTs measured at high frequency. Usually, the frequency spectra will exhibit very broadband excitations as shown in Fig. 1. It cannot be calculated exactly where the cavitation

vibrations are located. Online vibration monitoring or trial runs, however, make it possible to determine the frequency ranges. If the frequency bands and the associated cavitation types are known, equipment such as VIBNODE® can be used to monitor cavitation occurrence online. A warning is issued as soon as a vapor or gas cavitation takes place. PRÜFTECHNIK has accompanied pump manufacturers as they allocated frequency ranges such as these

and has defined discrete cavitation characteristic values. ■

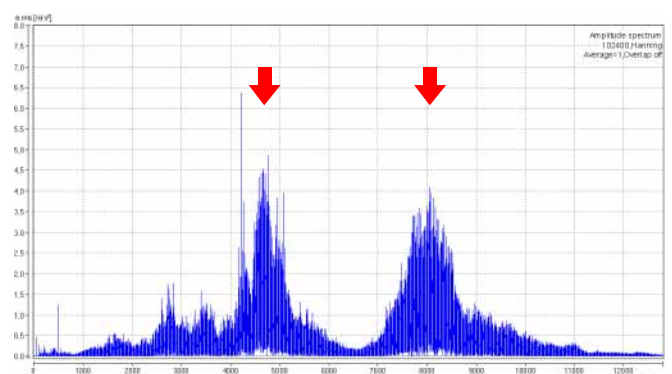

Fig. 1: High frequency acceleration spectrum with two cavitation occurrences



**Glossary of terms**  
Did you know?

**Sound:** Vibrations of media at frequencies from 16 Hz to 20 kHz are audible to the human ear. Sound can be classified as air-borne sound, structure-borne sound and water-borne sound.

**Pitch, timbre:** Pitch is indicated in the frequency spectrum by a single line. Timbre consists of multiple partial tones whose frequencies combine to a harmonic whole as perceived by the human ear.

**Noise:** Noise consists of randomly combined time functions and/or non-harmonic frequencies. It may be perceived as a nuisance or as a source of discomfort. The individual threshold for noise tolerance cannot be measured.

**Personal noise exposure:** A measure of the total noise received at the workplace averaged over an 8-hour shift or a 40-hour work week.

**Sound pressure:** The sound pressure is a time-dependent alternating pressure superimposed on the equilibrium pressure. The so-called A-weighting describes the hearing response.

**Sound particle velocity:** The sound particle velocity refers to the speed with which material particles oscillate in the sound medium.

**Sound intensity:** The product of the sound particle velocity and the sound pressure equals the sound intensity. It is expressed in units of power per unit area and provides a clear representation of the sound gradient.

**Level:** Because the values of the sound parameters extend over multiple factors of ten, a logarithmic scale is used in technical acoustics. It is expressed in decibels (dB). The equation used to calculate the sound level values has the following basic form:

$$L = 10 \cdot \log \frac{X}{X_0} \text{ [dB]}$$

(Measured value relative to the reference value  $X_0$ )

**Sound power level:** A machine-specific measure of the total radiated sound power of a sound source under constant operating conditions. The sound power level is dependent on the measurement room, distance and other noise sources.

**Frequency:** The frequency expresses the pitch of the sound in Hz. A doubling of the frequency is an octave or three third-octave steps. The hearing range covers ten octaves.

**Volume:** The sensitivity of the human ear varies with the frequency. Sounds of the same pressure but with different frequencies are perceived to have different volumes. To nevertheless obtain an adjusted noise characteristic value, the sound pressure is weighted as a function of the frequency. DIN 45633 mandates use of the A-weighting curve, identified by dB(A), for machinery construction and operation.

**Spectrum:** The spectrum displays the frequency components contained in a signal. It is used to analytically characterize a sound. There are octave, third-octave and narrow band spectra.

Condition Monitoring Application

# Analyzing causes of noise

Misel Tanasijevic

The noise radiation of a centrifugal pump can be used as a measure of its running characteristics. When unusual noise occurs, the noise levels and the third octave and narrow band spectra should be measured. To do so, VIBXPERT® and a microphone are used to measure the sound

level in the pumping medium. Our recommendation to the pump manufacturer was to check the lines, the intake cross-sections and the suction pressures in each case to reduce the vane excitation. ■

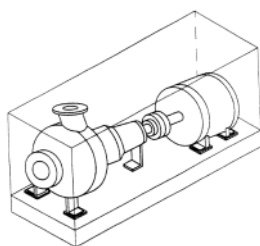
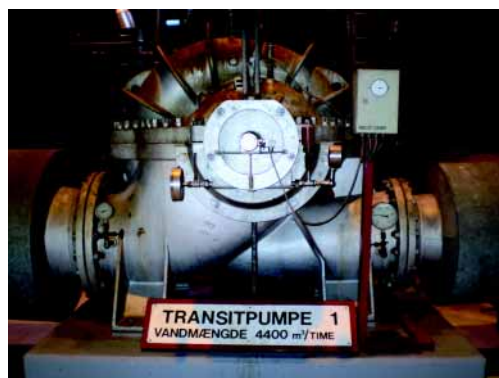

Fig. 1: Reference box as per EN12639:2000



pressure level on an enveloping surface at a distance of 1 m above the centrifugal pump. The resulting mean sound pressure level can then be calculated using DBSPECTRA® and compared with the agreed noise levels. Dominant exciters can be identified in the third octave band or on the basis of narrow band spectra in OMNI-TREND®.

### Example in a power plant

A variable speed centrifugal pump in a new power plant drew attention because it generated additional noise when operating in the range of 700 rpm. Measurements were taken at several speed levels and the customer's findings were verified.

### Result of acceptance measurement

At 700 rpm, the levels increased markedly and the 125 Hz, 250 Hz and 500 Hz third octave bands rose disproportionately. The cause was the vane pass frequency, as shown by the narrow band frequency spectra and order spectra. This indicated that there was turbu-

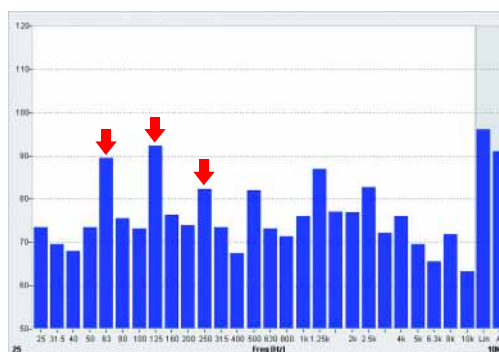

Figs. 2+3: Third octave spectrum of the sound pressure level of the above pumps with pronounced excitations at the vane pass frequency

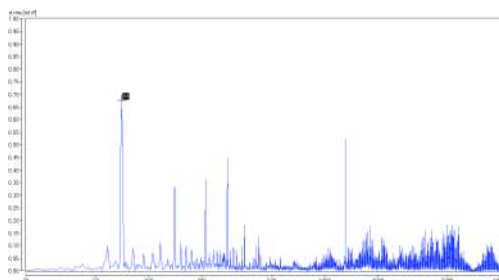

Fig. 4: Frequency spectrum with log. frequency axis

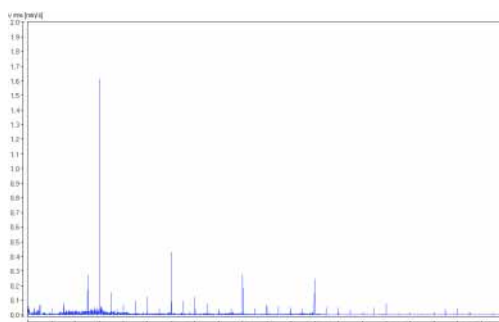

Fig. 5: Order spectra of the vibration velocity

Alignment Application

# Aligning vertical pumps and checking for plumbness

Bernardo Quintana

With eight pumped storage units and a rated power output of 320 MW, the pumped storage power plant at Hohenwarte II in Thuringia is the largest power plant on the Saale River. In times of excess power generation – generally at night – water is pumped into the elevated storage tank to make it available to the turbines for power generation during peak consumption.

## Vertical alignment with ROTALIGN® Ultra

As part of an inspection of machine C, PRÜFTECHNIK Machinery Service was contracted to align the shaft. The equipment of choice was ROTALIGN® Ultra, ideally suited for this type of machine with its functions for aligning vertical machines and for the wireless transmission of data between computer and sensor.

First, the gear coupling between the turbine and pump was disassembled and the laser and sensor were attached to the flange faces using magnetic clamping equipment (Figs. 2 and 3). To take the measurements, both shafts were rotated to the clock positions at 0(=elevated water storage)–3–6–9.

In the next set of measurements taken at the second coupling between the turbine and generator, the bearing clearance of the journal bearings had to be taken into account. The air gaps at the clock positions were filled with 0.4 mm shims.

The machinery was aligned with the aid of hydraulic presses by inserting shims at the radial bearings under the pump. Fig. 4 shows the alignment result. Alignment is now well within the tolerance specified for a speed of 428 rpm.

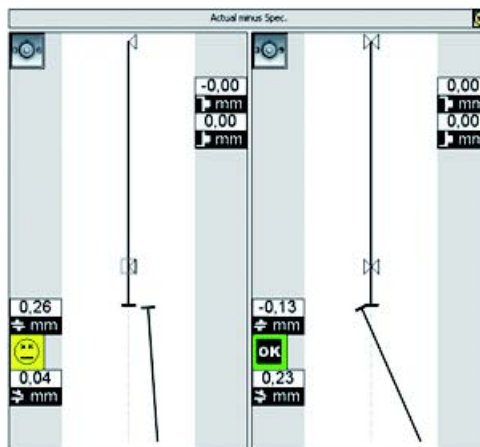

Fig. 4: Alignment result at machine C



Fig. 2: ROTALIGN® Ultra laser transmitter attached with a magnetic bracket



Fig. 3: Sensor attached with a magnetic bracket – equipped for wireless data transmission

## Plumbness measurement using INCLINEO®

The relative alignment of the shafts to each other is not the only criterion for large vertical machines. The plumbness of the shafts – i.e., the relationship between the rotating centerline to gravity – is also important. The tolerance



Fig. 5: Principle of plumbness measurement with INCLINEO®

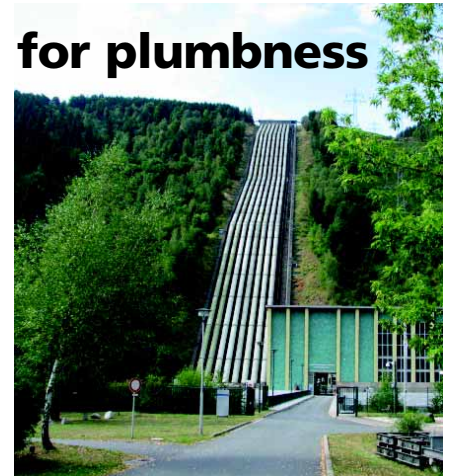

Fig. 1: Pumped storage power plant Hohenwarte

here is **0.02 mm/m**. If the shafts are not plumb, this will result in imbalances, vibrations, higher temperatures, a shorter bearing life span and/or lower efficiency.

The measurements were taken with the new INCLINEO®, a high-precision, electronic inclinometer. It is simple to attach to the shaft with its magnetic base. The value for the plumbness of the shaft was obtained by comparing two measurements at opposite positions.

The measurements were taken in two directions as well as at the 45° positions to ensure repeatability. These measurements were repeated at every



Fig. 6: Plumbness measurement on a vertical shaft with the INCLINEO®

section of the shaft, thus determining the position of the entire shaft relative to the plumb line.

If you require support for similar measurement tasks, our globally active Machinery Service will be glad to assist you. ■

Condition Monitoring Recommendations

# The toughest vibration standard for centrifugal pumps

Dr. Edwin Becker

After a suitable pump is selected, the running and operating behavior should be checked for vibration because often the machines that exhibit the least vibration are the better machines. But what measurement locations and acceptance criteria should be used for the vibration measurements? DIN EN ISO 13709 provides challenging answers. In the experience of PRÜFTECHNIK, this standard, entitled “Centrifugal pumps for petroleum, petrochemical and natural gas industries”, represents one of the toughest vibration standards for pump manufacturers.

## Type classes and measurement locations

The standard subdivides centrifugal pumps into 18 different type classes (see Table 1). In addition to the required dimensioning, it makes technical recommendations on housing design and indicates where vibration sensors should be mounted and where measurements should be taken. Fig. 2 shows acceptance-related measurement locations for pumps of type class OH1 and BB1. While it is sufficient to take measurements on the collar bearing in a horizontal, vertical and axial direction for the OH1 type, two additional measurement locations need to be used for the BB1.

## Allowable vibration values

In Chapter 5.9.3, ISO 13709 presents allowable vibration velocities (5 to 1000 Hz) that are power- and speed-related and specifies the frequency range in which the FFT spectra should be measured. For horizontal pumps working in the rated operating range, the vibrations may not exceed a value of 3.0 mm/s at power outputs of less than 300 kW and speeds of up to 3600 rpm. At higher speeds and outputs, the nomogram shown in Fig. 3 should be used. Vibrations greater than 4.5 mm/s are not allowable on horizontal pumps.

For vertical pumps, 5.0 mm/s is the upper limit. It should also be noted that, outside of the operating range for both types of pumps, a vibration increase of only 30% is tolerated.

Aside from the allowable vibration values, ISO 13709 also stipulates specific requirements for the structural and resonance behavior of centrifugal pumps and the necessary acceptance measurements.

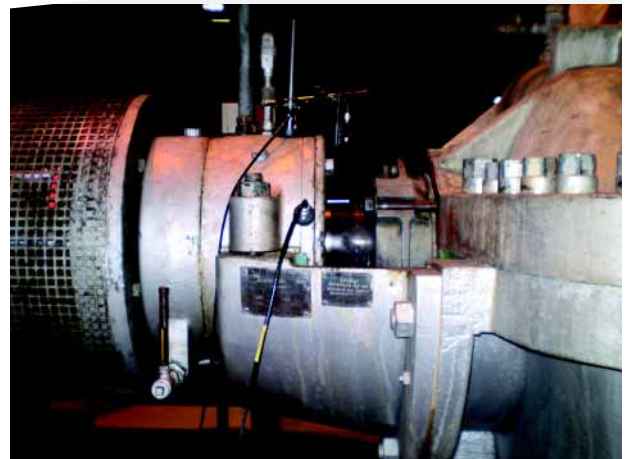

Fig. 1: Typical measurement locations for mobile measurements

More details can be found in the vibration specifications. ISO 13709 is available in English from the Beuth-Verlag (EUR 280). ■

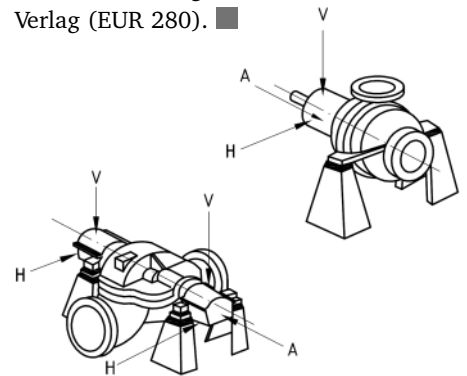

Fig. 2: Measurement locations for vibration measurement on centrifugal pumps of the OH1 and BB1 types

Table 1 — Pump classification type identification

Pump type		Orientation		Type code	
Centrifugal pumps	Overhung	Flexibly coupled	Horizontal	Foot-mounted	OH1
				Centreline-supported	OH2
			Vertical in-line with bearing bracket		OH3
		Rigidly coupled	Vertical in-line		OH4
			Vertical in-line		OH5
Vertically suspended	Between-bearings	Close-coupled	High-speed integrally geared		OH6
			1- and 2-stage	Axially split	BB1
			Radially split	BB2	
	Multistage	Axially split	BB3		
		Radially split	Single casing	BB4	
			Double casing	BB5	
		Vertically suspended	Single casing	Discharge through column	Diffuser
	Volute				VS2
	Axial flow				VS3
				Line shaft	VS4
Double casing	Separate discharge		Cantilever	VS5	
			Diffuser	VS6	
	Volute		VS7		

Taken from “Centrifugal pumps for petroleum, petrochemical and natural gas industries (ISO/DIS 13709:2007)”

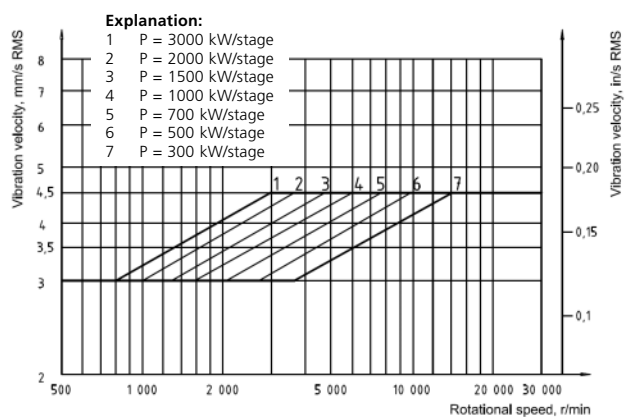

Fig. 3: Vibration thresholds for horizontal pumps that rotate faster than 3600 rpm and with a power input of over 400kW/stage.

## News

### VIBXPERT® now with coast-down spectra

When a pump is switched off, natural frequencies can be determined as it is coasting down. Instead of coast-down curves, VIBXPERT® can now be used to measure full coast-down spectra. They contain even more information. ■

### MEScope connection

ODS is the 'fine art' of Condition Monitoring. VIBXPERT® and MEScope now work together to be able to perform Operation Deflection Signal Analyses. ■

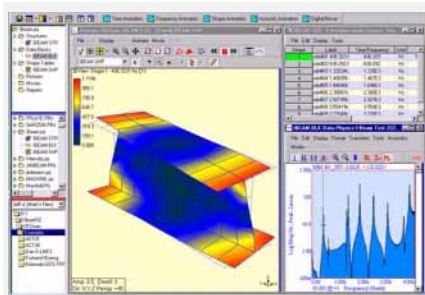

### VIBNODE® measures time records

VIBNODE® now has the facility to record time waveforms of the vibration velocities or accelerations – a unique feature for a low-cost CMS. ■

### OMNITREND® with vibration code, diagnosis code and correction code

Pumps can be systematized using machine codes and described by means of vibration, diagnosis and correction codes. PRÜFTECHNIK originally developed these tools for wind turbines. Vibration codes are used to evaluate vibration amplitudes. Diagnosis codes can be used to make standardized condition statements independent of language. Correction codes contain specific recommendations for the machine manufacturer or operator on how to improve machine availability. ■

## Dates

Information on all trade fairs, seminars and other important events of the PRÜFTECHNIK Group can be found on our website at [www.pruftechnik.com](http://www.pruftechnik.com) ■

### New laser speed sensor

PRÜFTECHNIK has introduced a new laser speed sensor onto the market. It can be used to measure speeds on very slow and very fast machines. A speed marker is attached as a reflector. The visible laser beam can be pointed to the reflector from distances of up to one meter and deliver precise speed values – when the equipment is being balanced, during resampling and for coast-down measurements. The package is rounded out with a quick-mount stand with a ball joint. ■

### WEARSCANNER®



For force-lubricated machines (also for pumps), the change in particle size distribution in oil is an important measure of machine condition. On the basis of eddy current technology, PRÜFTECHNIK has developed an autonomous sensor for determining particle sizes in up to 8 size classes. WEARSCANNER® is connected to the monitoring system or the system control unit via ModBus TCP. ■

### New service: noise measurement

The PRÜFTECHNIK Service and Diagnosis Center now performs noise measurement anywhere in the world and offers recommendations on noise reduction. ■

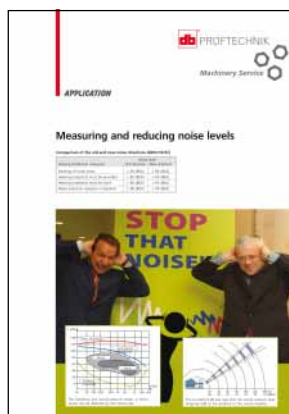

VIBXPERT® –  
the new two channel  
FFT data collector and signal  
analyzer for hazardous areas

for monitoring and diagnosing machine conditions in the chemical industry, in refineries, in the oil and gas industry and in any other potentially explosive environment that requires intrinsically safe measuring systems.

- ▷ Knowledge-based setups
- ▷ 102,400 lines of resolution
- ▷ Simple joystick operation
- ▷ Acceptance measurements
- ▷ Runup / coastdown analysis
- ▷ Time waveform analysis
- ▷ Balancing, 1 plane or 2 planes
- ▷ Intrinsic safety II 2 G EEx ib IIC T4

### Contact

**PRÜFTECHNIK**  
**Condition Monitoring GmbH**  
85737 Ismaning, Germany  
Fax: +49 89 99616-0  
Fax: +49 89 99616-341  
eMail: [info@pruftechnik.com](mailto:info@pruftechnik.com)

**PRÜFTECHNIK**  
**Alignment Systems GmbH**  
85737 Ismaning, Germany  
Tel: +49 89 99616-0  
Fax: +49 89 99616-100  
eMail: [info@pruftechnik.com](mailto:info@pruftechnik.com)

[www.pruftechnik.com](http://www.pruftechnik.com)