

### Features

- Time measurement for the accurate and repeatable determination of concentration, density and density-related physical quantities
- Certification: ATEX/IECEX zone 1
- Flameproof/explosion proof housing for hazardous areas
- Intrinsic safe process inputs for the integration of external pressure and temperature sensors
- Bidirectional communication and HART
- Two measuring channels

### Applications

For a wide range of fluids, e.g. H<sub>2</sub>SO<sub>4</sub>, HF, HCl, HNO<sub>3</sub>, sugar solution (Brix), brine in:

Chemical industry, petrochemical industry, oil and gas industry, pharmaceutical industry, semiconductor industry, mechanical and electrical industries, food industry



# Transmitter

## Technical data

<b>FLUXUS S831 (831-AA2)</b>	
	
design	explosion-proof field device zone 1 (intrinsic safety: inputs, HART)
<b>measurement</b>	
<b>• analysis</b>	
transit time (repeatable)	$1/(50 \cdot f_a) \pm 10^{-4} \cdot t$
transit time (absolute)	$1/(5 \cdot f_a) \pm 10^{-4} \cdot t$
	$f_a$ - transducer frequency, t - total transit time e.g. for transducers with transducer frequency M ( $f_a = 1$ MHz): repeatable: $20 \text{ ns} \pm 10^{-4} \cdot t$ , absolute: $200 \text{ ns} \pm 10^{-4} \cdot t$ The total measurement uncertainty of a physical quantity for analysis is supplied order-related as it depends on the fluid, operating range and installation. For the basis of calculation see document TIPIOX-S_uncert_analysis.
<b>• flow</b>	
measurement principle	transit time difference correlation principle
flow velocity	m/s 0.01...25
repeatability	0.15 % MV $\pm 0.005$ m/s
fluid	all acoustically conductive liquids with < 10 % gaseous or solid content in volume
temperature compensation	corresponding to the recommendations in ANSI/ASME MFC-5.1-2011
<b>measurement uncertainty (volumetric flow rate)</b>	
measurement uncertainty of the measuring system <sup>1</sup>	$\pm 0.3$ % MV $\pm 0.005$ m/s
measurement uncertainty at the measuring point <sup>2</sup>	$\pm 1$ % MV $\pm 0.005$ m/s
<b>transmitter</b>	
power supply	20...32 V DC, $U_m = 120$ V
power consumption	W < 4
number of measuring channels	1, optional: 2
damping	s 0...100 (adjustable)
measuring cycle	Hz 100...1000 (1 channel)
response time	s 1 (1 channel), option: 0.02
housing material	cast aluminum, special heavy-duty coating
degree of protection	IP66
dimensions	mm see dimensional drawing
weight	kg 6.5
fixation	wall mounting, 2" pipe mounting
ambient temperature	°C -40...+60 (< -20 without operation of the display)
display	128 x 64 pixels, backlight
menu language	English, German, French, Spanish, Dutch, Russian, Polish, Turkish, Italian
<b>explosion protection</b>	
<b>• ATEX/IECEX</b>	
marking	CE 0637 Ex II(1)2G II(1)2D Ex db eb ia [ia] IIC T6 Gb Ex tb ia [ia] IIC T100 °C Db T <sub>a</sub> -40...+60 °C
certification ATEX	IBExU20ATEX1103 X
certification IECEX	IECEX IBE 20.0015X
<b>measuring functions</b>	
physical quantities	see table below
totaliser	volume, mass
calculation functions	average, difference, sum (2 measuring channels necessary)
diagnostic functions	signal amplitude, SNR, SCNR, standard deviation of amplitudes and transit times
<b>communication interfaces</b>	
service interfaces	measured value transmission, parametrisation of the transmitter: USB <sup>3</sup>
process interfaces	HART (intrinsic safety, optional)

<sup>1</sup> with aperture calibration of the transducers

<sup>2</sup> for transit time difference principle and reference conditions

<sup>3</sup> outside the explosive atmosphere (housing cover open)

		FLUXUS S831 (831-AA2)
<b>accessories</b>		
data transmission kit		USB cable
software		<ul style="list-style-type: none"> <li>FluxDiagReader: reading of measured values and parameters, graphical presentation</li> <li>FluxDiag (optional): reading of measurement data, graphical presentation, report generation, parametrisation of the transmitter</li> </ul>
<b>data logger</b>		
loggable values		all physical quantities, totalised physical quantities and diagnostic values
capacity		max. 800 000 measured values
<b>outputs</b>		
<b>• current output</b>		
number		1
range	mA	4...20 (3.2...24)
accuracy		0.04 % MV ±3 µA
passive output		$U_{ext} \leq 29 \text{ V DC}$ , depending on $R_{ext}$ ( $R_{ext} < 830 \Omega$ at 29 V)
current output in HART mode		
• range	mA	4...20 (3.5...22)
• passive output		$U_{ext} = 9...29 \text{ V DC}$
intrinsic safety parameters		$U_i = 29 \text{ V}$ $I_i = 100 \text{ mA}$ $P_i = 0.725 \text{ W}$ $C_i = 1 \text{ nF}$ $L_i = 50 \text{ nH}$
<b>inputs</b>		
<b>• temperature input</b>		
number		max. 1
type		Pt100/Pt1000
connection		4-wire
range	°C	-150...+560
resolution	K	0.01
accuracy		
intrinsic safety parameters		$U_o = 9.2 \text{ V}$ $I_o = 25 \text{ mA}$ $P_o = 0.057 \text{ W}$ $C_o = 4283 \text{ nF}$ $L_o = 57 \text{ mH}$
<b>• current input</b>		
number		max. 1
accuracy		±0.1 % MV ±0.01 mA
active input		$U_{int} < 20 \text{ V}$ , $R_{int} = 360 \Omega$
• range	mA	0...20
intrinsic safety parameters		$U_o = 29.2 \text{ V}$ $I_o = 88 \text{ mA}$ $P_o = 0.64 \text{ W}$ $C_o = 73 \text{ nF}$ $L_o = 4.1 \text{ mH}$

<sup>1</sup> with aperture calibration of the transducers

<sup>2</sup> for transit time difference principle and reference conditions

<sup>3</sup> outside the explosive atmosphere (housing cover open)

## Physical quantities

The available physical quantities depend on the fluid data set in the transmitter.

fluid data set	physical quantities	remark	
NN	no fluid data set	• sound speed, volumetric flow rate	
MD	standard fluid data set	• analysis <sup>1</sup> : concentration, mass fraction, volume fraction, density, normalised density, normalised sound speed, sound speed • flow: volumetric flow rate, flow velocity, mass flow rate	application-specific fluid data set from FLEXIM database
CU	customised fluid data set	• analysis <sup>1</sup> : concentration, mass fraction, volume fraction, density, normalised density, normalised sound speed, sound speed • flow: volumetric flow rate, flow velocity, mass flow rate • further customised physical quantities <sup>1</sup>	data set developed by FLEXIM in cooperation with the customer

<sup>1</sup> min. 1 input or process interface with inputs necessary for fluid temperature

## Dimensions

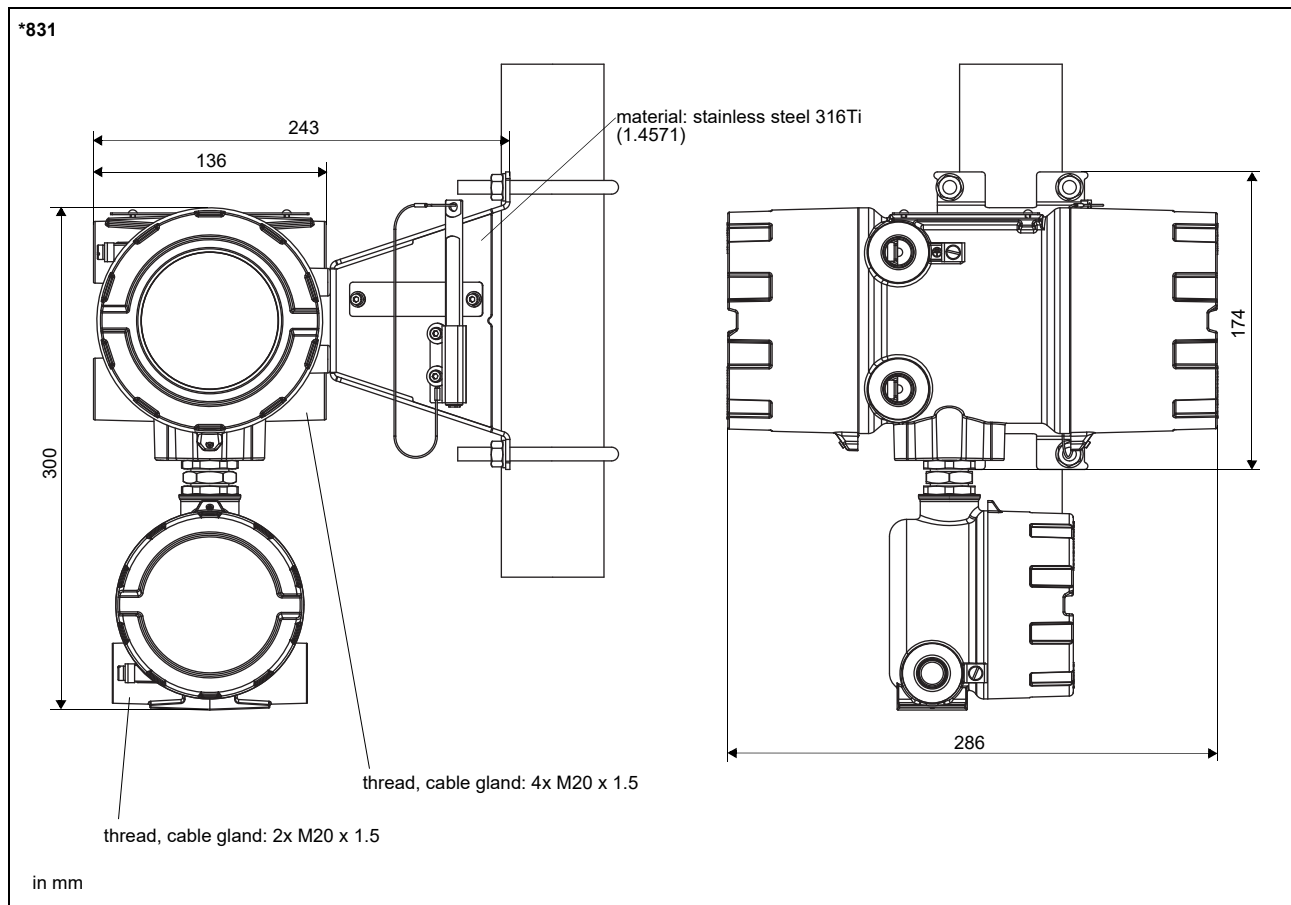

## 2" pipe mounting kit

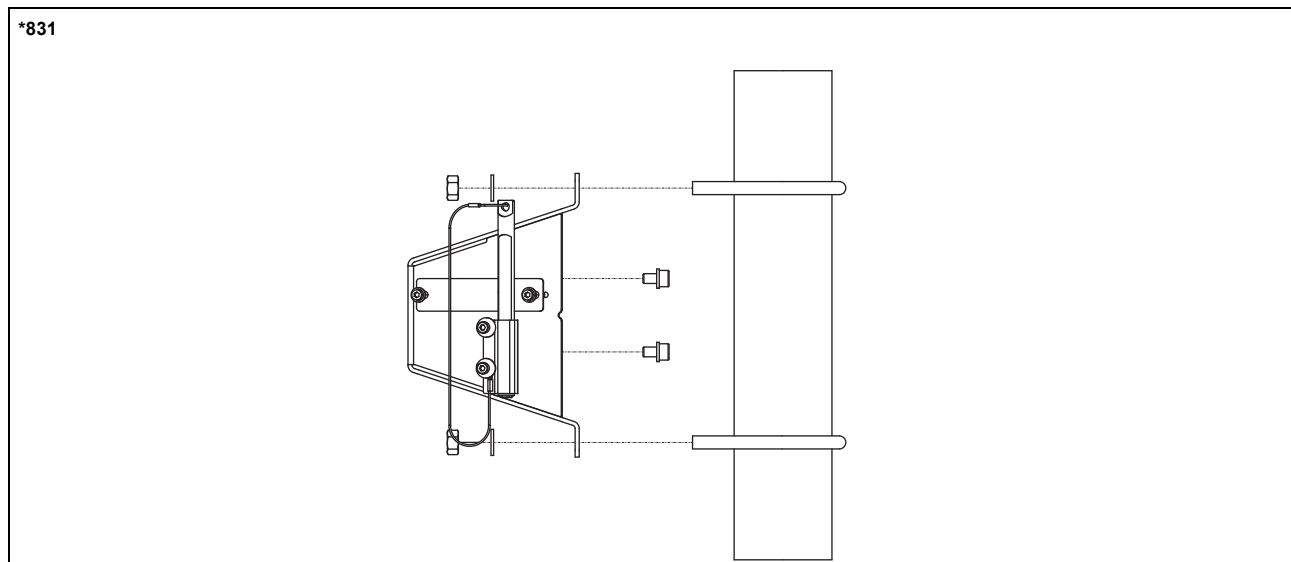

## Storage

- do not store outdoors
- store within the original package
- store in a dry and dust-free place
- protect against sunlight
- keep all openings closed
- storing temperature: -40...+60 °C

## Terminal assignment

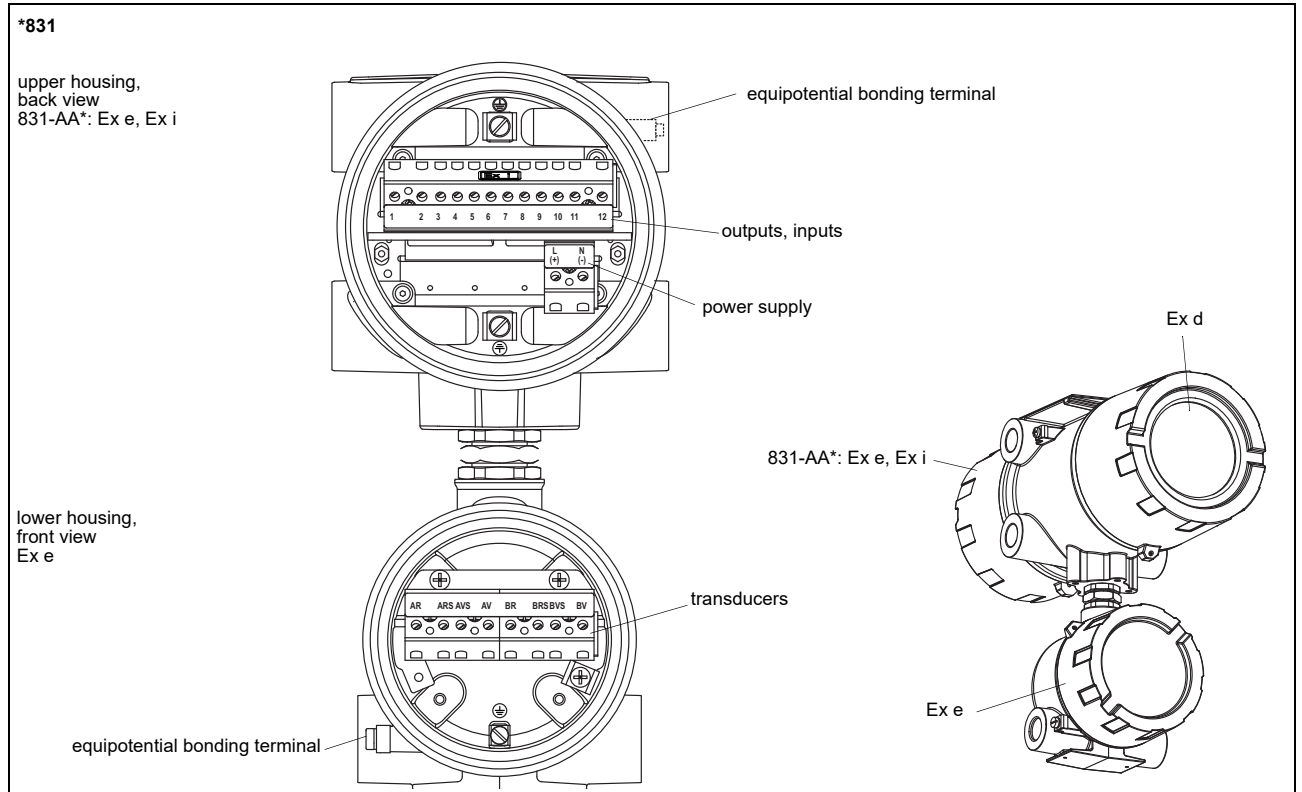

power supply <sup>1</sup>				
<b>DC</b>				
<b>terminal</b>		<b>connection</b>		
(+) (+)		+		
(-) (-)		-		
transducers, extension cable				
measuring channel A		measuring channel B		transducer
terminal	connection	terminal	connection	
AV	signal	BV	signal	↑
AVS	internal shield	BVS	internal shield	↕
ARS	internal shield	BRS	internal shield	↕
AR	signal	BR	signal	↑
cable gland	external shield	cable gland	external shield	↑ ↕
outputs <sup>1, 2</sup>				
<b>terminal</b>		<b>connection</b>		
11+, 12-		current output, HART		
USB		type C Hi-Speed USB 2.0 Device	service (FluxDiag/FluxDiagReader)	
inputs <sup>2</sup>				
temperature probe				
<b>terminal</b>		<b>direct connection</b>	<b>connection with extension cable</b>	
3		red	red	
4		red/blue	blue	
5		white/blue	grey	
6		white	white	
current input <sup>1</sup>				
<b>terminal</b>		<b>connection</b>		
1		-		
2		+		

<sup>1</sup> cable (by customer): e.g. flexible wires, with insulated wire ferrules, wire cross-section: 0.25...2.5 mm<sup>2</sup>

<sup>2</sup> The number, type and terminal assignment are customised.

## Transducers



### Overview

#### Shear wave transducers

		technical type				
		G	K	M	P	Q
<b>zone 1 normal temperature range</b>		CDG1N81 CLG1N81	CDK1N81 CLK1N81	CDM2N81 CLM2N81	CDP2N81 CLP2N81	CDQ2N81 CLQ2N81
<b>zone 1 IP68</b>		CDG1L11	CDK1L11	CDM2L11	CDP2L11	
<b>zone 1 extended temperature range</b>		CDG1E83 CLG1E83	CDK1E83 CLK1E83	CDM2E85 CLM2E85	CDP2E85 CLP2E85	CDQ2E85 CLQ2E85
<b>inner pipe diameter d</b>						
min. extended	mm	400	100	50	25	10
min. recommended	mm	500	200	100	50	25
max. recommended	mm	4000	2000	1000	400	150
max. extended	mm	6500	2400	1200	480	240
<b>pipe wall thickness</b>						
min.	mm	11	5	2.5	1.2	0.6

for further data see Technical specification TS\_F8xx-transducersVx-xxx\_Leu

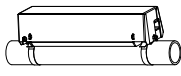
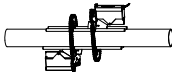
#### Transducer mounting fixture

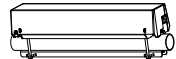
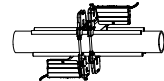
<b>Variofix L</b>	<b>Variofix C</b>	<b>transducer box WI for Wavelnjector with chains</b>
		
<b>Variofix L with bolt mounting plates</b>	<b>Variofix C with bolt mounting plates</b>	<b>transducer box WI for Wavelnjector with threaded rods</b>
		
outer pipe diameter: max. 48 mm	outer pipe diameter: <b>VCM:</b> max. 46 mm <b>VCC:</b> max. 36 mm	outer pipe diameter: 35...380 mm

for further data see Technical specification TS\_F8xx-transducersVx-xxx\_Leu

#### Coupling materials for transducers

	normal temperature range		extended temperature range			Wavelnjector WI-400	
	< 100 °C	< 170 °C	< 150 °C	< 200 °C	200...240 °C	< 280 °C	280...400 °C
< 24 h	coupling compound type N or coupling foil type VT	coupling compound type E or coupling foil type VT	coupling compound type E or coupling foil type VT	coupling compound type E or H or coupling foil type VT	coupling foil type TF	coupling foil type A and coupling foil type VT	coupling foil type B and coupling foil type VT
long time measurement	coupling foil type VT	coupling foil type VT	coupling foil type VT	coupling foil type VT			

for further data see Technical specification TS\_F8xx-transducersVx-xxx\_Leu

### Connection systems

connection system T1		
connection with extension cable	direct connection	transducers technical type
<p>JB01</p>		<p>****g*</p>
<p>JB01</p>		<p>****L1*</p>

for further data see Technical specification TS\_F8xx-transducersVx-xxx\_Leu

## Temperature probes

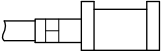
<b>PT12N (order code: ACC-PE-xxxx-/T332)</b>
<ul style="list-style-type: none"><li>• clamp-on</li><li>• ATEX zone 0 (intrinsic safety)</li></ul>
-45...+230 °C

see Technical specification TS\_PTVx-xxx\_Leu